

ORIGAMI | THE CREASING GURU

The innovative 3D digital printing station to create creasing and embossing clichés without any outsourcing.

Origami is an innovative, proprietary creasing/ embossing system exploiting a male/female concept. A stand-alone 3D digital printing station that allows to quickly and simply create creasing and embossing plates without any outsourcing. The creasing quality is equal to that of traditional professional creasing.

It is a unique and proprietary solution for the complete digitalization of the production process that enables to maximize versatility and flexibility for a faster and lean production.

The graphic designer only generates a digital file that is directly imported by SEI proprietary software thanks to the new 3D printing control algorithm. The creasing matrix is 100% reusable and recyclable and the entire workflow starts following the digital file designed by the graphic.

Origami offers the possibility to create state-of-the-art three-dimensional clichés for linear and

curved creasing and embossing optimizing the costs. Consumable materials have an extremely low impact/cost on the entire process, for both medium-sized runs, and especially small or very small ones.

Origami is a future-oriented system that offers three-dimensional finishing thanks to digital technology on paper and folding carton. It is possible to use a single Origami printer, or multiple printing stations, to produce many clichés in a few minutes: the entire process and the print buffer are automatically managed by the digital workflow.

Male/female creasing

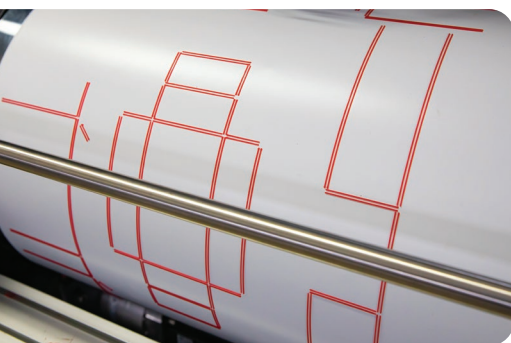



ORIGAMI

Main technical features:

Printing station			
Power supply	230V, 50/60 HZ, single phase		
Average consumption	500 W		
Size (mm)	L: 2166, W: 1191, H: 1497		
Weight (Kg)	560		
3D Technology	Multilayer deposit of molten thermoplastic polymer		
X,Y,Z,E axis motorization	4 interpolated axis (2 brushless +2 stepper motors)		
Axis movement	Rotative digital technology		
Encoder resolution (mm)	X: $7,63 \times 10^{-6}$	Y: $7,63 \times 10^{-6}$	Z: $1,95 \times 10^{-5}$
Accuracy and repeatability (mm)	X: 0,05	Y: 0,05	Z: 0,02
Plates			
Plate size	B1+: 760 x 1120 mm - B2: 500 x 707 mm		
Creasing shape	Proprietary algorithm		
Plate support	Proprietary multilayer flexible magnetic plate support		
Creasing	Polymer male/female matrix		
Deposit technology	Proprietary algorithm		
Dimension of the male/female creasing profiles	Proprietary algorithm		
Software e hardware control			
Control Unit	PC		
Operating system	Windows 10		
Control application	Icaro CUT, SEI proprietary software		
Motion	3 interpolated axis motion controlled by SEI proprietary electronic board (EtherCAT fieldbus)		
Diagnostics	Proprietary diagnostics and remote connection		

L 2166 mm | W 1191 mm | H 1497 mm

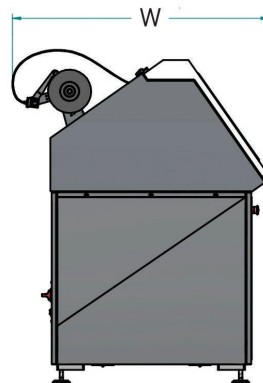
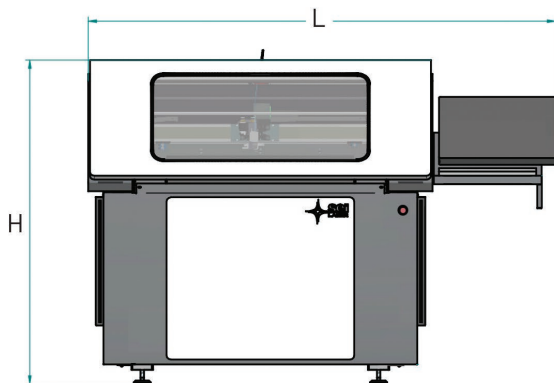

Digital workflow

