



# MERCURY FIBER

## Accuracy, productivity and reliability in the metal cutting industry

- **Mercury Fiber** is a laser system specially designed to cut low and medium thickness metal and alloy sheets.
- **Mercury Fiber** is equipped with a high power fiber laser whose beam can be adapted according to customer's application needs.
- **Mercury Fiber** is equipped with linear motors, that guarantee the most dynamic performances and repeatability in the cutting shapes.
- **Mercury Fiber** is extremely flexible: this system is full of options to meet all customer' needs and fit all production process.
- The operator can access the working area from three sides, ensuring versatility in the process.
- **Mercury Fiber** is a Class 1 laser system: it can be integrated in all shop floors thanks to its hood and suction system, making the environment safe and clean.

- Icaro software (CAD/CAM) is user friendly and enables operators to import files and configure the system in just a few steps, ensuring seamless integration with the most widely used CAD/CAM platforms on the market.

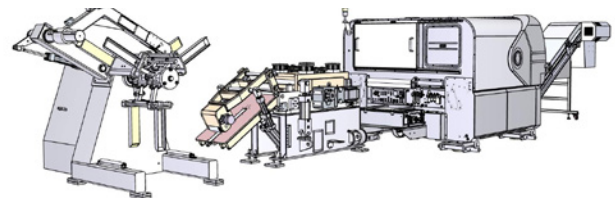
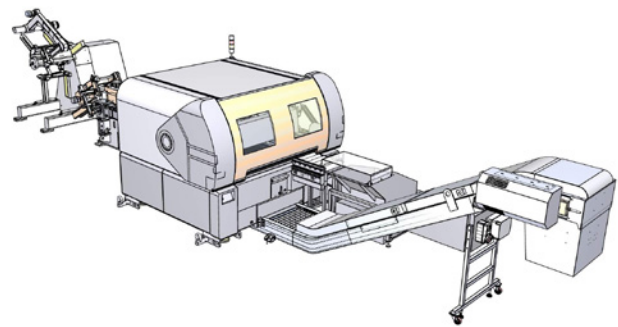

*Coil option*

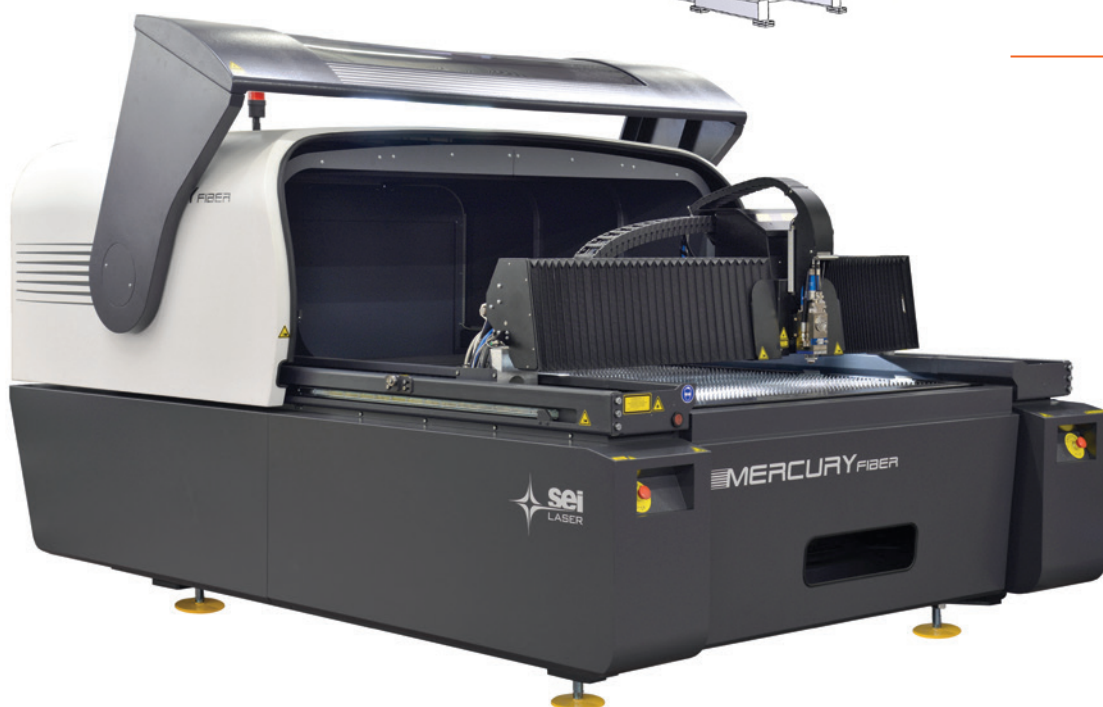



# MERCURY FIBER

## Main technical features:

Configurations	1208	1215	1520	1530	2040
Working area (mm)	1250 x 800	1250 x 1500	1500 x 2000	1500 x 3080	2000 x 4000
Laser power (W)	1000, 1500, 2000, 3000, 4000				
Repeatability (mm)	< 0.05				
Max. acceleration (m/s <sup>2</sup> )	up to 20				
Axes resolution (mm)	0.001				
Precision (mm)	+/- 0.05				
Vector files import	.dxf, .plt, .eps, .ai, .pdf, .iso				
Raster files import	.bmp, .jpeg				
Software interface	Icaro CAD/CAM				
Norm compliance	2014/35/UE Low Voltage Directive				
	2006/42/CE Machinery Directive				
	2014/30/UE Electromagnetic Compatibility Directive				
	IEC EN 60825-1 Laser Safety				



## Options:

- Motorized waste collector and fully automatic waste separation system;
- CCD Camera for registry process and live view;
- Coil option to automatically load the material and ensure high production yields;
- Unwinder / collecting system;
- Elevator and mobile worktop;
- Sheet locking clamps;
- Rotary device to to handle cylindrical objects;
- Hardening kit;

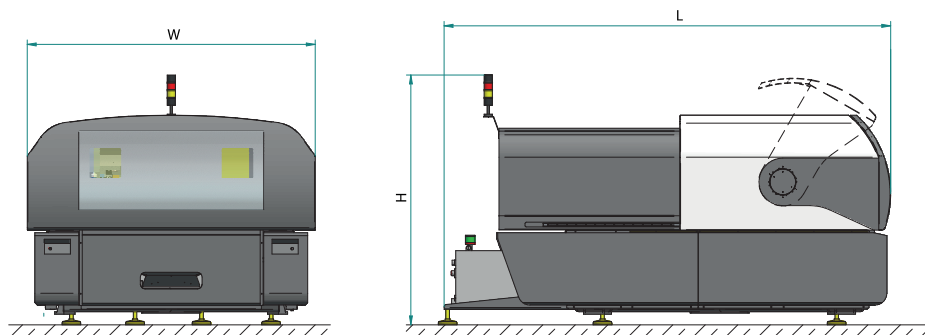

	1208	1215	1520	1530	2040
<b>L</b>	2110	3800	4090	5050	5650
<b>W</b>	2356	2430	2750	2750	3370
<b>H</b>	2226	2150	2150	2150	2150